

DC-27

33" Sleeper



DC-27

Add a Sleeper to your Classic Ride



Integrating a sleeper into an already existing tractor can present challenges, particularly with regards to the often-limited swing clearance of the trailer. However, with our innovative solution, the DC-27, has been specifically engineered to provide ample interior space for a restful night's sleep without using up your precious frame space. With its ultra-light panel construction, the DC-27 adds less than 200 lbs. to your Gross Vehicle Weight, ensuring minimal impact on your GCWR.



DC-27

Big Benefits in a Small Package



The DC-27 Sleeper offers the convenience of fitting a spacious 24" legal width mattress for added comfort. Additionally, drivers can easily access the side compartments both inside and outside the sleeper, as well as conveniently store items under the open center section. The interior of the DC-27 is designed to be fully customizable according to your preferences, allowing you to personalize it to suit your individual needs and preferences.

DC-27

Add a Sleeper to your MD



Incorporating a sleeper into a medium-duty truck can revolutionize the way you work. With the DC-27, your remote working trucks gain a new level of versatility and convenience. By adding a sleeper, you can now comfortably rest during long trips, Running Hot-Shot or moving furniture you can say goodbye to expensive hotel rooms and hello to a more cost-effective solution with the DC-27 sleeper.



DC-27

LAY BACK AND RELAX



Truck drivers often endure long hours on the road, and their shifts become even more taxing when their vehicles are not comfortable. Providing drivers with spacious accommodations can help alleviate discomfort and prevent the development of chronic health problems.

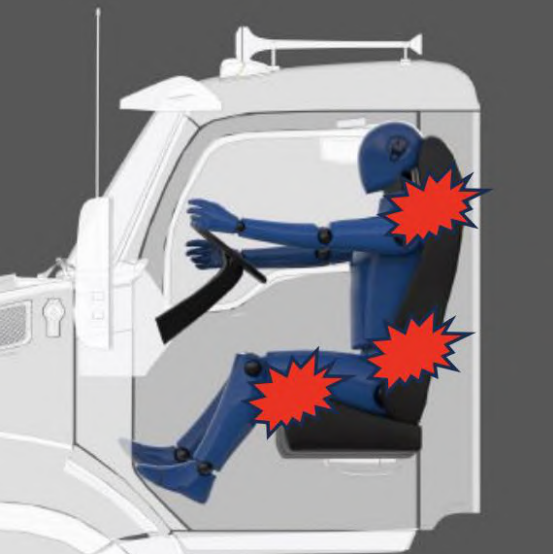

Increase the seat recline angle to eliminate the uncomfortable straight-up driving position. Enhance legroom to allow for stretching out long legs and provide additional body room between the driver and the steering wheel.



DC-27

Details & Dimensions



Access
Doors



Side Skirts



Windows



5.5"

8.5"

Side shields are sized based on the truck model. See OEM model flyers for more info



Sleeper
Bunk

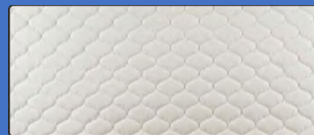

Standard 24"
mattress

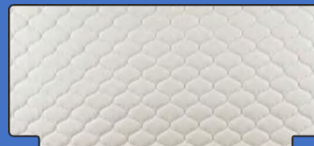

Max wide 27"
mattress

Option		DC-27
Box	Base Box	\$8,700
Doors	Single Side Door	\$350
	Dual Side Doors	\$700
Cabinets	Sleeper Bunk	\$1,500
	Omit Bunk	\$0
Windows	Rear Window	\$350
	Single Side Window	\$250
	Dual Side Windows	\$500
Side Skirts	Stainless	\$593
	Painted	\$593
Back Light Bar	Stainless	\$553
	Painted	\$553
Mattress	Std 24"	\$300
	Ultra wide 27"	\$400
Paint	Paint Ready	\$0
	Base White	\$2,174
	Color matched	\$2,717

DC-27

Details & Dimensions



DC-27 Size Chart				
OEM	Models	Back of Cab (A)	Width (B)	Height (C)
PACCAR	New Pete	27.5"	81.75"	59.75"
	New KW	27.5"	81.75"	59.75"
	Classic Pete	27.5"	77.5"	58.5"
	Classic KW	27.5"	77.5"	58.5"
Daimler	M2	27.5"	81.75"	59.75"
	Cascadia	27.5"	87"	64.5"
	WS 49X	27.5"	87"	62.5"
	Coronado	27.5"	77.5"	64.5"
	Constellation	27.5"	77.5"	64.5"
International	All Models	27.5"	81.75"	59.75"

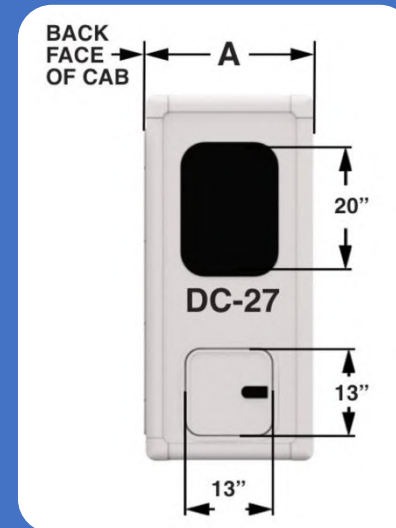
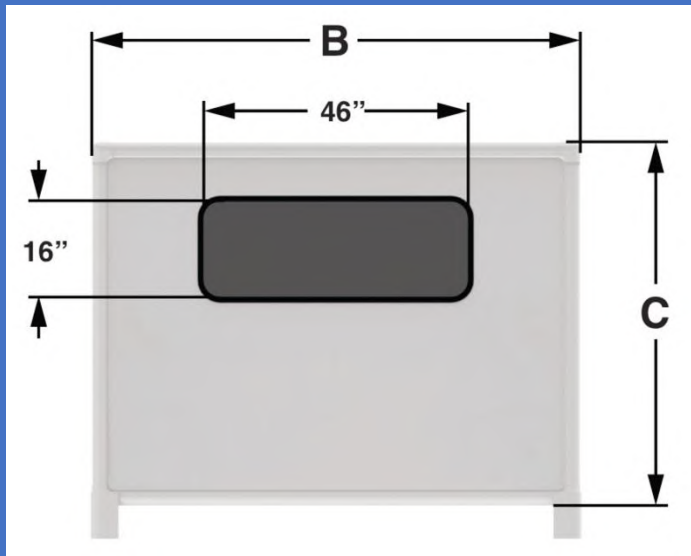

DC-27

Calculate Your Swing Clearance

