

PETERBILT-MD

MODEL	MODEL	MODEL	MODEL
548	537	536	535



DC-10

MAXIMIZE FRAME SPACE



The DC-10 offers the perfect solution for drivers needing more room in the cab. With a DC-10, you get more leg room, seat recline, and belly room. The extra space allows more functional space in the cab for a center console, lunch box, or dry out your wet coat and boots. Add a back wall door and stop climbing in and out of your cab to get your stuff.



DC-16

MAXIMIZE YOUR ACCESS



The DC-16 adds 32 cu ft of cab functional cab space with tall side doors into the cab for easy access from the outside. Individual interior compartments or a through cabinet style with hinged dual lids are available on this model.

The DC-16 has a minimum weight impact adding only 140 lbs when installed. It also offers clear frame access to the factory rear cab mount allowing room for long body mounts.



DC-22

MAXIMIZE YOUR ACCESS



The DC-22 provides ample room to handle everything from paperwork to safety gear and equipment for the entire crew. Side doors offer easy access from the ground to prevent slip accidents. Large side windows supply a complete view of the driver's surroundings.

The perfect solution for small tow trucks and municipal, utility, and service trucks. The DC-22 increases the cab space by 46 cu ft of fully customizable space. The through cabinet is accessible from inside or outside.



DC-27

LAY BACK AND RELAX



The DC-27 Rest cab sleeper lets you add a comfortable 24" wide mattress and a customizable vocational interior. Drivers can access the side compartments inside and out and store items under the open center section. Add windows for better visibility omit the rear window to add more wall space to hang up a few things. With DC-Max you can order it just the way you want it



The DC-27 offers a great new sleeper option for the Medium duty product. Whether you are running a hot shot truck or need some place to lay down in your moving van the DC-27 is just what you need



DIMENSIONS & DETAILS

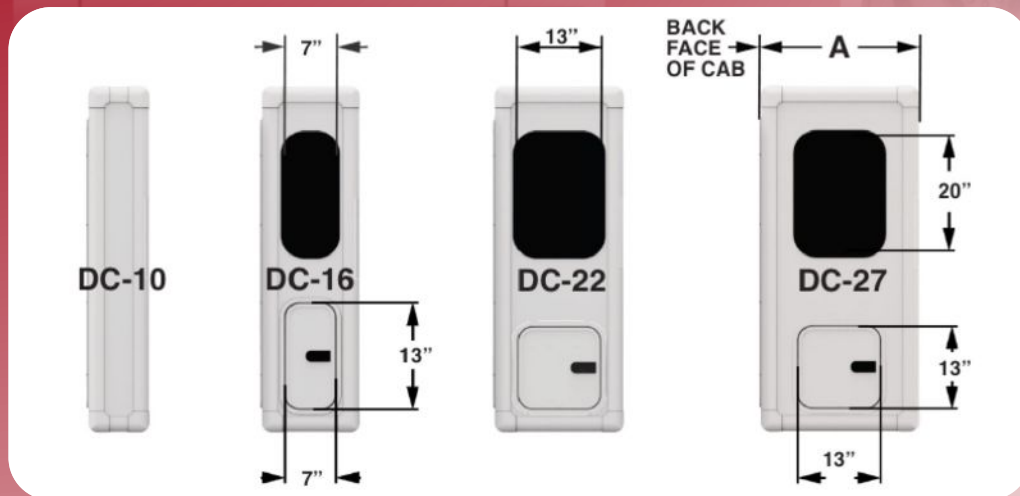
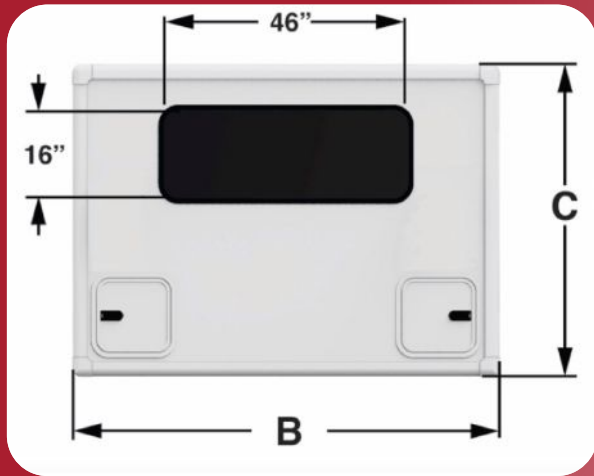

	A	B	C
DC-10	11"	81.75"	59.75"
DC-16	17.5"	81.75"	59.75"
DC-22	22.5"	81.75"	59.75"
DC-27	27"	81.75"	59.75"