

CASCADIA



DC-10

A FEW INCHES MAKES
A BIG DIFFERENCE TO YOUR DRIVERS



Making a driver's day better impacts where and when they come to work.

The DC-10 offers the drivers more room in the cab and gives them the best office in town.

A DC-10 gives you more leg room, seat recline, and belly room without compromising frame space or valuable GVW. Adding less than 100lb, the DC-10 can be easily installed on your current trucks or new units. DC-10 is a perfect driver environment that will leave your competition's drivers green with envy.

Easily accessible back wall doors let drivers put coats and gloves inside after chaining up and give them quick access to emergency signal flares and fire extinguishers.



DC-16

THE PLACE FOR YOUR STUFF, AND ACCESS TO IT



The DC-16 is an excellent option for customers seeking a more functional room with side door access. The DC-16 doors are 18" tall, allowing larger items like overnight bags and clothing to be easily stowed and accessed from inside with our through cabinet option. Eliminating the constant climbing into the cab for items reduces accident claims due to slip hazards.

Interior compartments that act as a spot to firmly affix paperwork storage shelves inside and keep objects stored inside cabinet from flying around in the cab should an incident occur.



DC-22

GET MORE DISTANCE OUT OF YOUR DAY CABS



The DC-22 adds as little as 160 lbs. (depending on options) to your weight-conscious ride. Every pound counts when you hook up to your load, and the DC Max offers an excellent, low-weight, and compact solution to enhance your current-day cab to a far more spacious solution that enhances driver comfort and storage solutions. Add in the option flexibility that allows you to mix and match windows, doors, and interior cabinets, and you have a winning combination for your new or existing fleet.



DC-27

GET MORE DISTANCE OUT OF YOUR DAY CABS



The DC-27 Rest cab sleeper lets you add a FMVSS legal 24" wide mattress and a customizable vocational interior on to your exiting bob tail unit. Drivers who have long layovers or are traveling out of town occasionally, will love the flexibility the DC-27 provides. can access the side compartments inside and out and store items under the open center section. Add windows for more light and better visibility or omit the windows and your drivers can use the wall space to hang up a few things.

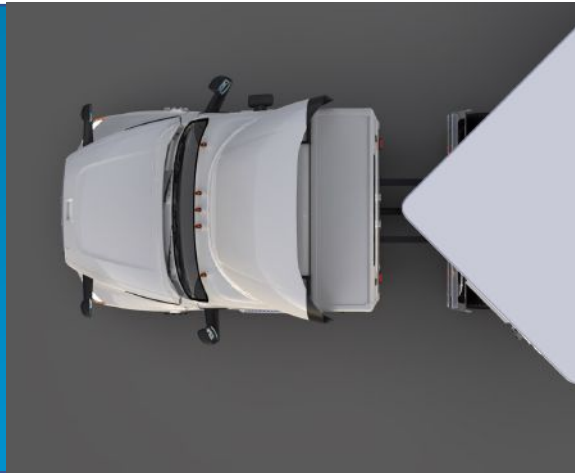

DIMENSIONS & DETAILS

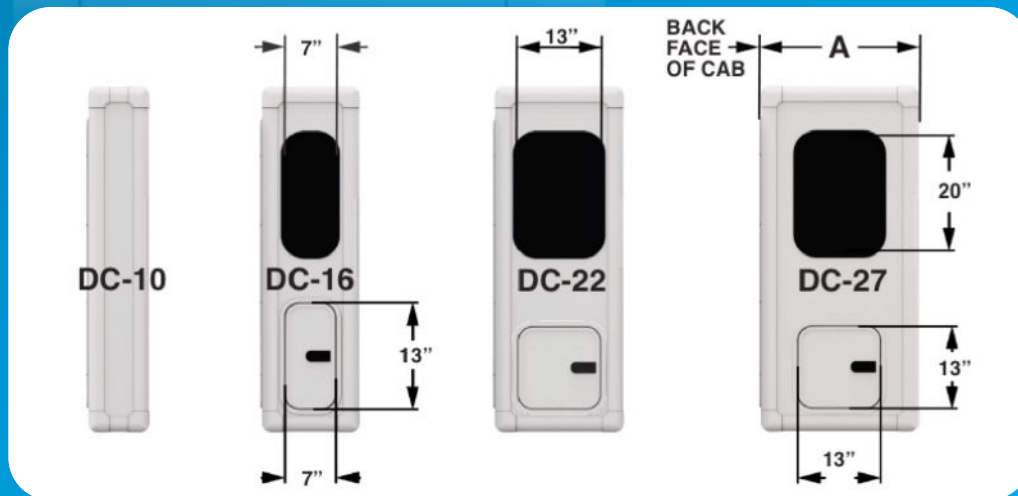
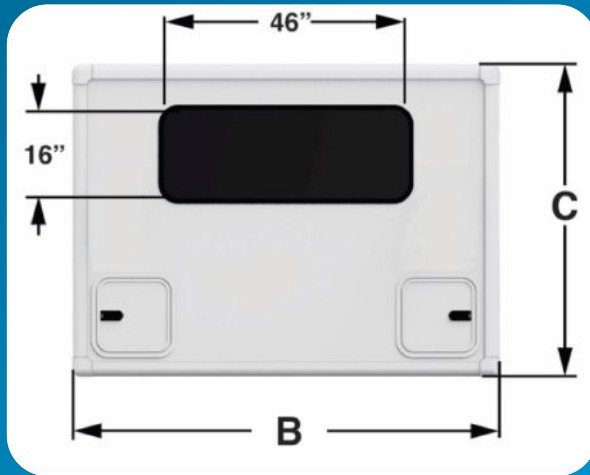

	A	B	C
DC-10	11"	87"	67"
DC-16	17.5"	87"	67"
DC-22	22.5"	87"	67"
DC-27	27"	87"	67"